

### Micro Cabinet EMLock® Security Made Easy

SDC's 1583 Micro Cabinet EMLock® is a compact specialized electromagnetic lock that produces 300lbs. of holding force. Versatile mounting capability with face drilled and surface mounting holes. The 1583 operating voltage is field selectable for either 12/24 VDC. Aluminum housing is standard.

#### Applications

- Cabinets
- Drawers
- Display cases
- Machine equipment housings
- Gun safes
- Package pass through doors
- Dark rooms

#### Failsafe Operation

Security and safety with no moving parts. Positive and instantaneous failsafe un-locking operation is guaranteed.

#### Easy Installation

Compact size allows easy installation in small cabinets or restricted spaces. No special tools are required.

#### Durable, No Maintenance

With nothing to wear out and no moving parts, the 1583 EMLock® is virtually maintenance free.

#### Solid State Protection

The EMLock® provides spike and surge protection for solid-state devices on the same line.

#### Features

- 300lbs. of holding force
- An electronics module provides spike and surge protection for the EMLock®
- Dual voltage and modular design
- Strong enough even for large cabinet doors
- Protection of the EMLock® and other devices on same line without additional parts
- Operates on 12 or 24VDC

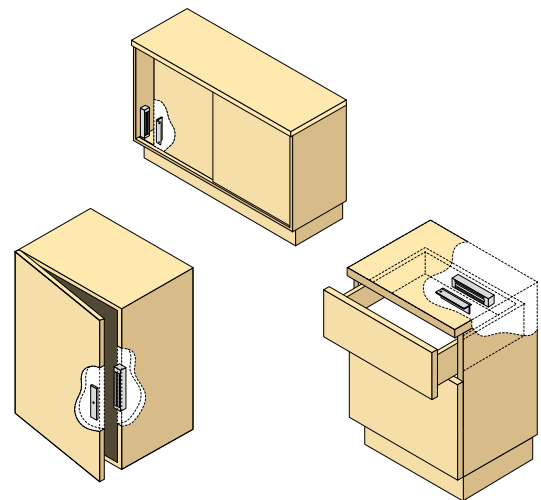

#### Specifications

**1583V** EMLock® 300lbs. holding force, 12/24VDC

#### Dimensions

EMLock®: 6.5"L x 1.125"W x 1.5"H  
(159 x 29 x 38mm)

Armature: 5.125"L x 1.125"W x 0.25"H  
(130 x 29 x 6mm)

#### Electrical Specifications

Connection: Wire leads with in-line spike and surge protection

Input Voltage: 12 or 24 VDC +/- 10%

Current: 500mA @ 12VDC  
250mA @ 24 VDC

Battery back up capability when used with a power supply and battery.

**Note: Not recommended for life safety on pedestrian doors.**



**Figure 1. 1583 EMLock® Dimensions**

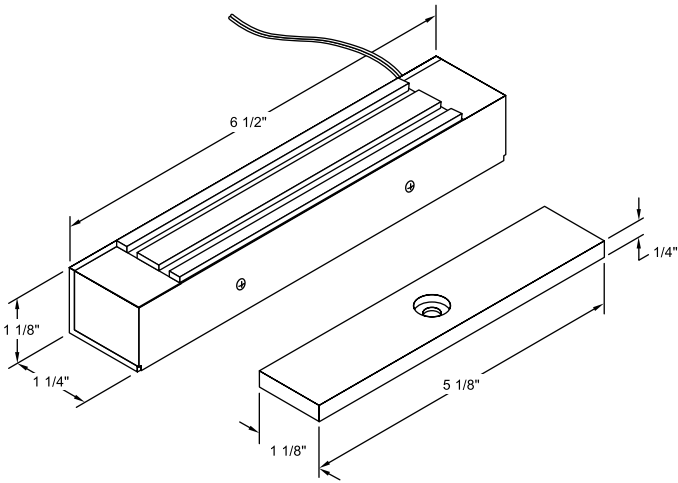

**Figure 2. 1583 EMLock® with AC transformer, rectifier, key switch and LED (green when locked, red when unlocked)**

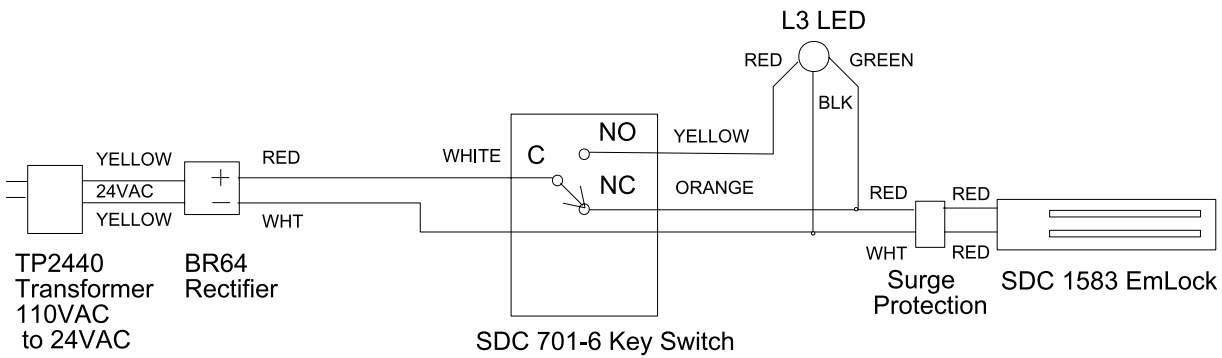

**Figure 3. 1583 EMLock® with DC plug-in transformer and SDC 917 keypad**

