

IXS0 Series Sarix™ Network Camera

0.5 MEGA PIXEL STANDARD DEFINITION DIGITAL CAMERAS

Product Features

- Open IP Standards
- Up to SVGA Resolution (800 x 600)
- Up to 30 Images per Second (ips) at All Resolutions
- Auto Back Focus
- H.264, MJPEG, and MPEG-4 Compression Capability
- Color and Day/Night Models
- Video Setup Jack
- Sensitivity Down to 0.03 lux
- Power over Ethernet (IEEE 802.3af) or 24 VAC
- Up to 2 Simultaneous Video Streams
- Web Viewing, up to 16 Cameras Simultaneously
- Local Storage (Mini SD) for Alarm Capture

The **IXS0 Series with Sarix™** technology is a standard definition network camera designed with industry-leading image quality and high performance processing power. Designed to install quickly, the camera comes equipped with the advanced features needed for demanding security applications.

Sarix technology defines the next generation of video security imaging performance, delivering high resolution, advanced lowlight capabilities, consistent color science, and fast processing power. The H.264 compression video files are up to 20 times smaller making network video storage more affordable.

Camera

The **IXS0 Series** has two standard definition models: color and day/night. Both models feature advanced low light technology capabilities. The day/night model has a mechanical IR cut filter for increased sensitivity in low light installations.

The **IXS0 Series** can support two simultaneous video streams. The two streams can be compressed in MJPEG, MPEG-4, and H.264 formats across several resolution configurations. The streams can be configured to a variety of frame rates, bit rates, and GOP (group of pictures) structures for additional bandwidth administration.



(LENS NOT SUPPLIED WITH CAMERA)

The **IXS0 Series** is simple to install, and the automatic back focus control feature makes sharp scene focus setup easy. A convenient video setup jack eliminates the need to use a laptop for viewing video when installing the camera.

The **IXS0 Series** features built-in Power over Ethernet (PoE) IEEE 802.3af, which supplies power to the camera over the network, eliminating the need for a separate power supply. If PoE is not available, 24 VAC can be used to power the camera.

Web Interface

The **IXS0 Series** uses a standard Web browser for powerful remote setup and administration. Up to 16 cameras can be viewed on the same network.

Network protocols such as SSL configuration for security certificates, SSH for remote logon, and QoS for priority or guarantee data flow can be managed using a Web browser.

Systemization

The **IXS0 Series** easily connects to Pelco IP and hybrid systems such as Endura® version 1.5 (or later), MPEG-4 or version 2.0 (or later), H.264; Digital Sentry® version 4.2 (or later); DX8100 version 2.0 (or later); and DVR5100 version 1.5.4 (or later). The camera also features open architecture connectivity to third-party software. Pelco offers an application programming interface (API) for interfacing to Pelco's network cameras.



TECHNICAL SPECIFICATIONS

GENERAL

Imaging Device	
16:9 Aspect Ratio	1/3-inch (effective)
4:3 and 5:4 Aspect Ratio	1/4-inch (effective)
Imager Type	CMOS
Imager Readout	Progressive scan
Maximum Resolution	800 x 600
Signal-to-Noise Ratio	50 dB
Auto Iris Lens Type	DC drive
Electronic Shutter Range	1~1/10,000 sec
Wide Dynamic Range	60 dB
White Balance Range	2,000° to 10,000°K
Sensitivity	f/1.2; 2,850°K; SNR >24 dB
Color (33 ms)	0.50 Lux
Color SENS (500 ms)	0.12 Lux
Mono (33 ms)	0.25 Lux
Mono SENS (500 ms)	0.03 Lux
Weight (without lens)	1.11 lb (0.5 kg)
Shipping Weight	2.00 lb (0.9 kg)

ELECTRICAL

Port	RJ-45 connector for 100Base-TX Auto MDI/MDI-X
Cabling Type	Cat5 or better for 100Base-TX
Power Input	24 VAC or PoE (IEEE 802.3af class 3)
Power Consumption	<6 W
Current Consumption	
PoE	<200 mA maximum
24 VAC	<295 mA nominal; <390 mA maximum
Local Storage	Mini SD
Alarm Input	10 VDC maximum, 5 mA maximum
Alarm Output	0 to 15 VDC maximum, 75 mA maximum
Service Connector	External 3-connector, 2.5 mm provides NTSC/PAL video output

MECHANICAL

Lens Mount	CS mount, adjustable
Camera Mount	0.25-inch (0.64 cm) UNC-20 screw, top and bottom of camera housing

ENVIRONMENTAL

Operational Temperature	14° to 122°F (-10° to 50°C)
Storage Temperature	14° to 158°F (-10° to 70°C)
Storage Humidity	20% to 90%, noncondensing



**FRONT VIEW, CAMERA ONLY
(OPENED TO EXPOSE SERVICE CONNECTOR)**

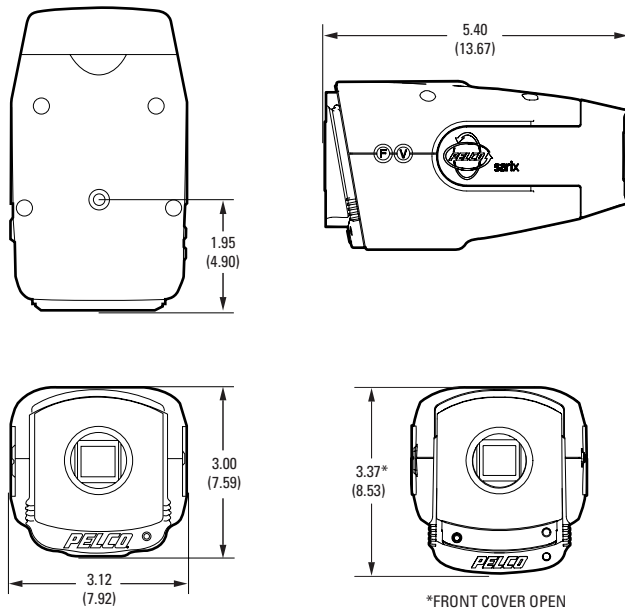

NOTE: VALUES IN PARENTHESES ARE CENTIMETERS; ALL OTHERS ARE INCHES.



REAR VIEW

TECHNICAL SPECIFICATIONS

VIDEO

Video Encoding H.264 base profile, MPEG-4, MJPEG

Video Streams Up to 2 simultaneous streams; the second stream is variable based on the setup of the primary stream

Frame Rate Up to 30, 25, 24, 15, 12.5, 12, 10, 8, 7.5, 6, 5, 4, 3, 2.5, 2, 1 (dependent upon coding, resolution, and stream configuration)

Resolution	Resolution			MJPEG		H.264 Base Profile		MPEG-4		
	MPx	Width	Height	Aspect Ratio	Maximum IPS	Recommended Bit Rate	Maximum IPS	Recommended Bit Rate	Maximum IPS	Recommended Bit Rate
	0.5	800	600	4:3	30 ips	5.8 Mbps	25 ips	1.6 Mbps	N/A	N/A
	0.3	640	480	4:3	30 ips	3.7 Mbps	30 ips	1.6 Mbps	30 ips	1.7 Mbps
	0.1	320	240	4:3	30 ips	0.9 Mbps	30 ips	0.4 Mbps	30 ips	0.4 Mbps

Additional Resolutions 640 x 512, 640 x 352, 480 x 368, 480 x 272, 320 x 256, 320 x 176, 4CIF (704 x 480 and 704 x 576), and CIF (352 x 240 and 352 x 288)

Supported Protocols TCP/IP, UDP/IP (Unicast, Multicast IGMP), UPnP, DNS, DHCP, RTP, RTSP, NTP, IPv4, SNMP, QoS, HTTP, HTTPS, LDAP (client), SSH, SSL, SMTP, FTP, MDNS (Bonjour)

Users
 Unicast Up to 20 simultaneous users
 Multicast Unlimited users H.264 or MPEG-4

Security Access Password protected

Software Interface Web browser view and setup, up to 16 cameras

Pelco System Integration Endura 1.5 (or later), MPEG-4 or Endura 2.0 (or later), H.264
 Digital Sentry 4.2 (or later)
 DVR5100 Series 1.5.4 (or later)
 DX8100 Series 2.0 (or later)

Open IP Integration Pelco IP camera API

Minimum Web Browser Requirements PC (Pentium® 4 microprocessor, 1.6 GHz) with Windows® XP, and Windows Vista®, or Mac® OS X 10.4 (or later)

Web User Interface Interface for viewing requires QuickTime® 7.55 (or later)

RAM 512 MB

Ethernet Card 100 Megabits

Web Browser Microsoft® Internet Explorer® 7.0 (or later) or Mozilla® Firefox® 3.0 (or later)

Screen Resolution 1024 x 768 pixels or higher, 16- or 32-bit pixel color resolution

TECHNICAL SPECIFICATIONS

MODELS

IXSOC	Sarix SVGA 0.5 megapixel network color camera
IXSODN	Sarix SVGA 0.5 megapixel network day/night camera

CERTIFICATIONS

- CE, Class B
- FCC, Class B
- UL/cUL Listed
- C-Tick*
- GOST*

*At the time of this printing, these certifications are pending. Please consult the factory, our Web site (www.pelco.com), or the most recent B.O.S.S.[®] update for the current status of certifications.

ACCESSORIES

IX-SC	4-foot Sarix service cable; compatible with standard BNC connectors
-------	---

RECOMMENDED MOUNTS

C10-UM	Universal camera mount
--------	------------------------

RECOMMENDED ENCLOSURES

EH1512	Indoor/outdoor enclosure
EH3512	Outdoor enclosure
DF8	8-inch fixed mount dome

RECOMMENDED LENSES

13VD2.5-6	Varifocal lens, 2.5–6.0 mm, f/1.4–2.1
13VD2.8-12	Varifocal lens, 2.8–12.0 mm, f/1.4–2.9
13VD3-8	Varifocal lens, 3.0–8.0 mm, f/1.0–1.4
13VD5-50	Varifocal lens, 5.0–50.0 mm, f/1.4–2.9

Field of View in Degrees		Aspect Ratio		
		16:9	4:3	5:4
2.5 mm	Horizontal	98	83	80
	Vertical	55	63	64
2.8 mm	Horizontal	89	74	71
	Vertical	48	55	56
3.0 mm	Horizontal	82	69	67
	Vertical	46	52	53
5.0 mm	Horizontal	50	42	40
	Vertical	28	32	32
6.0 mm	Horizontal	42	36	34
	Vertical	24	27	28
8.0 mm	Horizontal	32	27	26
	Vertical	18	20	20
12.0 mm	Horizontal	21	18	17
	Vertical	12	13	14
50.0 mm	Horizontal	5	4	4
	Vertical	3	3	3

Pelco, Inc. Worldwide Headquarters:

3500 Pelco Way, Clovis, California 93612-5699 USA

USA & Canada Tel: (800) 289-9100 • FAX: (800) 289-9150

International Tel: +1 (559) 292-1981 • FAX: +1 (559) 348-1120

www.pelco.com

Pelco, the Pelco logo, B.O.S.S., Digital Sentry, and Endura are registered trademarks of Pelco, Inc. Sarix is a trademark of Pelco, Inc. All product names and services identified throughout this document are trademarks or registered trademarks of their respective companies. The absence of a trademark or registered trademark from this document does not constitute a waiver of intellectual property rights. Product specifications and availability subject to change without notice. ©Copyright 2009, Pelco, Inc. All rights reserved.